







# Fenix™ HL30

Fenix HL30 is a high-intensity headlamp equipped with two light sources. Featuring four distinct brightness levels, HL30 is effective in a wide range of challenging lighting situations. It employs a dual switch for quick output changes that include red light and SOS modes.

Powered by two readily available AA batteries, it can deliver a max 200 lumen output with a runtime of up to 140hours and a max 40m throwing distance. Featuring waterproofing to IPX-6 Standard and the portable integrated design, Fenix HL30 must be able to ensure you a joyful and relaxing outdoor experience in various conditions.

## Technical Parameters

ANSI/FSC	General Mode				Red light Mode	SOS
	Turbo	High	Mid	Low		
 OUTPUT	200 LUMENS	100 LUMENS	45 LUMENS	4 LUMENS	—	45 LUMENS
 RUNTIME	1h 40min	4h 30min	10h30min	140h	—	—
 DISTANCE	40m					
 INTENSITY	475cd					
 IMPACT RESISTANT	1m					
 WATERPROOF	IPX-6(using a shower nozzle with a diameter of 12.5mm to spray water to the product for 3 minutes at a distance of 2.5~3m from the spray head (the flux is 100 (1±5%) L/min)					
EXTRA FUNCTION						
ACCESSORY	headlamp strap, top headlamp strap, the mount of the top headlamp strap and spare o-ring					

© Cree XP-G (R5) LED and Nichia red light (Nichia) LED, with a lifespan of 50,000 hours respectively

© Uses two 1.5V AA (Ni-MH, Alkaline) batteries

© 70mm (Length) x 55.7mm (Width) x 37.8mm (Height)



© 86.6-gram weight (excluding batteries and headlamp straps)

- ◎ Digitally regulated output maintains constant brightness
- ◎ Fast, convenient dual-button switch
- ◎ Reverse polarity protection guards against improper battery installation
- ◎ Made from durable aluminum alloy and performance plastic

Notice: The above-mentioned parameters (lab-tested with 2500mAh Ni-MH batteries) are approximate and may vary between individual headlamps, batteries and environments.

Safety setting: Fenix HL30 will automatically downshift into the HIGH brightness level after running continually for 5 minutes in TURBO. The rated runtime of the TURBO mode reflects this pre-programmed shift to HIGH.

### Operation Instruction

The button with the  mark is the power switch button and the one with  mark is the mode switch button.

Press the power switch button to turn on the headlamp. Press it once to turn it off.

With the headlamp off

A single press on the mode switch button activates the red light mode;

- ① Press the mode switch button once again to turn the headlamp off;
- ② A single press on the power switch button can change into the general mode.

With the headlamp on,

A single press on the mode switch button allows switching between:

Turbo→Low→Mid→High→brightness levels.

Press and hold the mode switch button for about one second to activate the red light mode.

Press and hold the mode switch button for about 3 seconds to activate the SOS mode.

While in red light or SOS mode, a single press on the mode switch button returns the HL30 to general mode.

HL30 memorizes the brightness level, not the mode, while in the general mode. When turned off and then on, the headlamp automatically enters the general mode.

Overheating protection: HL30 is a high-performance lighting system that can become hot to the touch when operated for long periods at high brightness levels. To avoid overheating the headlamp, HL30 will downshift from TURBO to HIGH after five minutes of use. If TURBO is needed for extended periods, simply reset it, recognizing heat build-up is probable.

### Battery Specifications

Type	Dimensions	Nominal voltage	Usability	
Ni-MH battery	AA	1.2V	Recommended	✓
Alkaline battery	AA	1.5V	Usable	✓
Non-rechargeable Battery (Lithium)	AA	1.5V	Usable	✓
Rechargeable Battery (Li-ion)	14500	3.7V	Banned	×

## Battery replacement

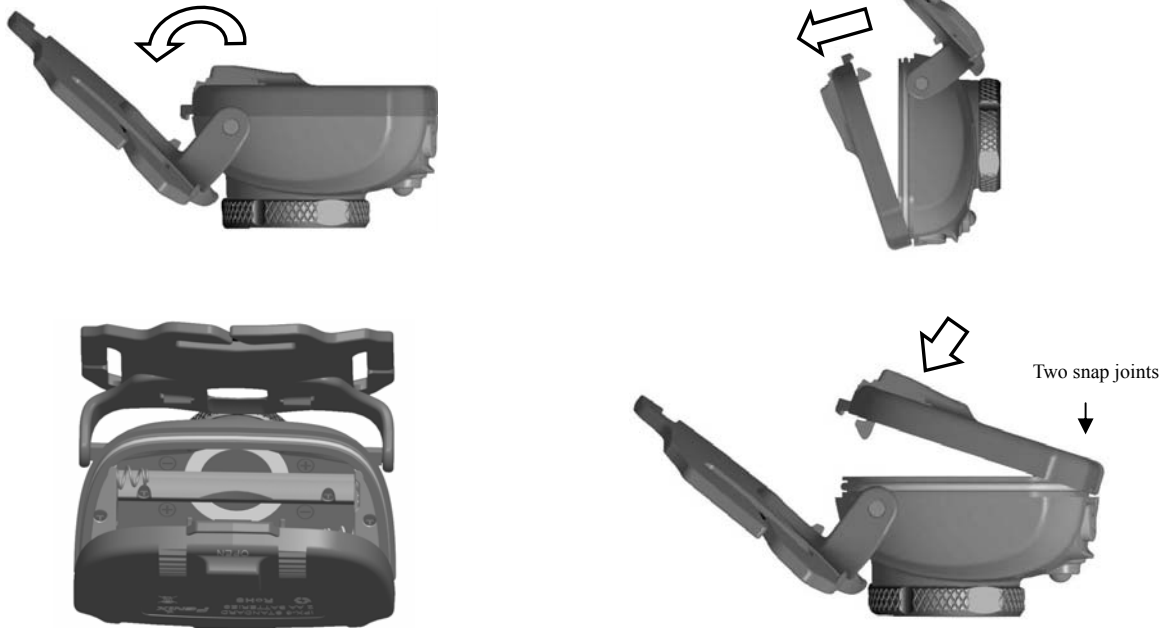

- ① Pull the headlamp bracket open as the arrow indicates till it is separated from the base as shown above .
- ② Hold back the protrusions on the back cover with your fingers ( as “open” indicates), and then pull the back cover open.
- ③ Insert the nominal batteries with the cathode side (—) toward the spring.
- ④ Put the two snap joints towards each other, and then securely replace the cover before testing the HL30’s power and functions.

## Assemble Headlamp Strap

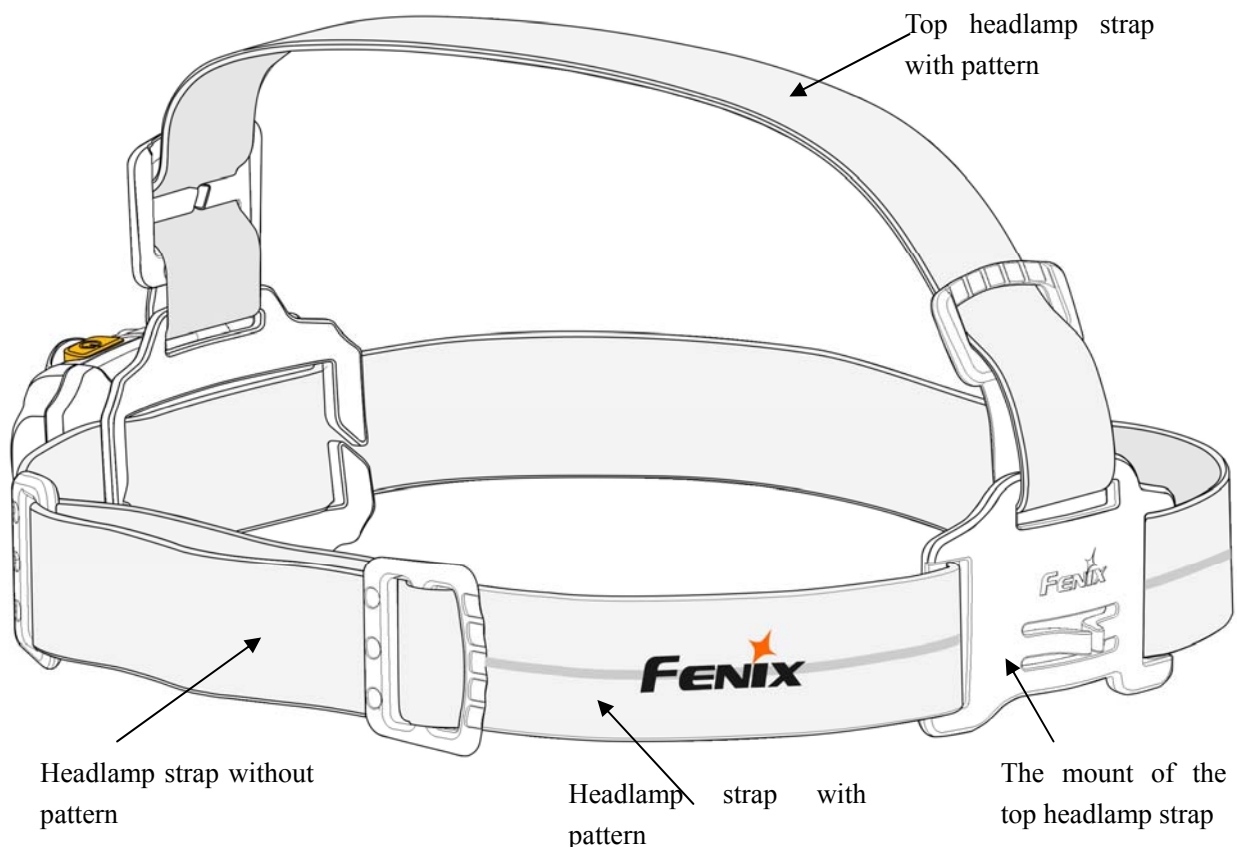

## Usage and Maintenance

- © Please do not disassemble the sealed head, doing so can cause damage to the light and will void the warranty.
  - © High-power light should use battery with high current discharge capability; We suggest using high-performance Ni-MH rechargeable battery, using alkaline battery will decrease the runtime of this high-intensity light.
  - © Please use batteries of high quality, and take out the battery if you do not use the light for a long time, or the light can be damaged by electrolyte leakage or battery explosion which is caused by low quality battery.
  - © The o-ring may be worn out after using for a long time. If it happens, please replace the o-ring with a new one to keep the light properly sealed against water.
  - © Please clean the contacts of your light from time to time, especially if the light flickers or doesn't light up. There may be several reasons for a flickering or not working light:  
Reason A: The battery needs replacing.  
Solution: Replace the battery (Please confirm the correct installation of anode and cathode).  
Reason B: The threads, PCB board contact or other contacts are dirty.  
Solution: Clean the contact points with an alcohol soaked cotton swab.
- If the above methods don't work, please contact the distributors and refer to the warranty policy.
- Notice: The routine cleaning video can be watched and downloaded through Fenix official website, please log onto the service channel->'maintenance for light'.

### **Product Warranty**

We will replace products afflicted with manufacturing defects within 15 days of purchase and repair a light free of charge within 24 months of purchase if problems develop with normal use; if repair is required after 24 months from the date of purchase, we will charge for parts. The total repair fee is dictated by the cost of the replaced materials.

### **Warranty Card Registration**

We kindly suggest that you register your guarantee card on the official website of Fenixlight Limited. You can get an extra six-month warranty period once you have successfully registered. What's more, you could take part in the lottery of questionnaire at the same time.

### **Warning**

HL30 is a high-intensity lighting device and capable of causing eye damage, avoid shining the light directly into the eyes.

FENIXLIGHT LIMITED

Tel: +86-755-29631163/83/93      Fax: +86-755-29631181

<http://www.fenixlight.com>

E-mail: [info@fenixlight.com](mailto:info@fenixlight.com)

Address: 8/F, 2nd Building, Dong Fang Ming

Industrial Center, 33rd District, Bao' an,

Shenzhen 518133, China